

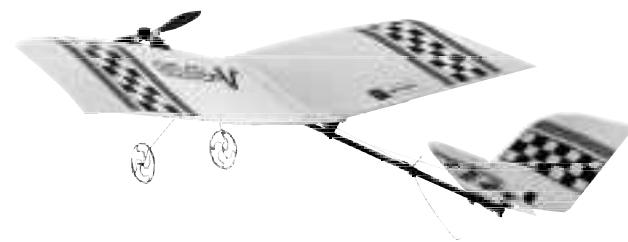

SLO-V™

Instruction Manual



PKZ1315

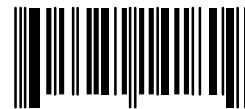

Charge-and-Fly™ Park Flyer

Wing Span: 46 in (1170mm)
Length: 36 in (930mm)
Weight: 15 oz (425 g)
Motor: 370 w/gearbox

FM Radio: 3 proportional channels
Battery: 7.2V 600mAh Ni-MH
Charger: DC peak detect

Visit www.modelflight.com.au for more information and spare parts.

Slo-V Instruction Manual

Congratulations on your purchase of the ParkZone™ Slo-V.™ Your Slo-V has come with everything needed to get you in the air –all in one box! You will only need to attach the wing and tail, as well as charge the flight battery prior to taking flight.

We at ParkZone are committed to giving you the most enjoyable flight experience you can have. In order to have a safe and successful flight, we ask that you do not fly until you have read these instructions thoroughly.

Your Slo-V comes with a fully proportional 3-channel FM radio system with full control of throttle, steering, and pitch. If you have not successfully flown one of HobbyZone's Zone 1 or 2 aircraft, or any other radio controlled aircraft, we recommend that you seek the help of an experienced radio control pilot during your beginning flights.

Crash damage is not covered under the warranty!

Step 1

Inspection of Contents

Carefully remove all contents, including the fuselage, tail, wing, radio, landing gear, and small parts bag. Ensure no damage had been done to any of the contents. If you notice some damage that may have occurred from shipping, immediately return it to the place of purchase.

Step 2

Transmitter

1. Insert 8 new "AA" batteries (supplied) into the transmitter, observing proper polarity.
2. Turn switch on to ensure the batteries have been installed correctly. Once this is confirmed, turn radio off.

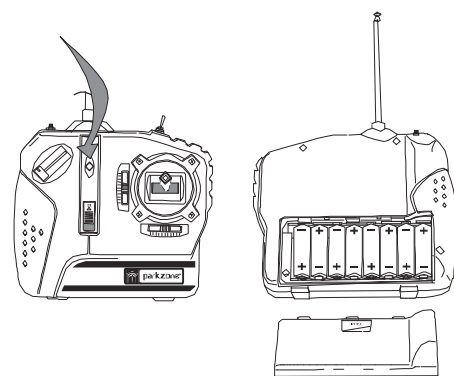

Step 3

Charging the Aircraft Battery

Your ParkZone charger uses unique peak detection circuitry that ensures an accurate charge every time and protects your Ni-Cd and Ni-MH batteries from the dangers of over-charging. During the charge cycle, it continuously monitors the charge curve and automatically switches to trickle charge when the peak is detected.

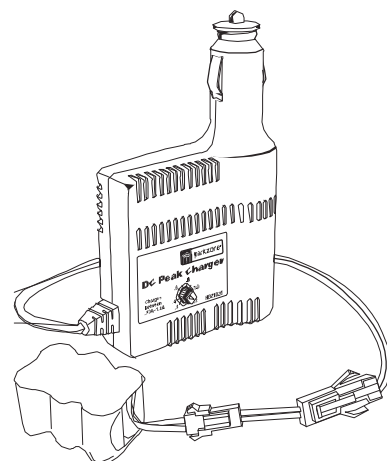

Step 3 continued

BATTERY CAPACITY	MAX. CHARGE RATE	CHARGE TIME
6V 300mAh Ni-MH	.4 amps	40 minutes
4.8V—8.4V 600mAh Ni-MH	.8 amps	40 minutes
7.2V—8.4V 900mAh Ni-MH	1.2 amps	40 minutes

Note: Charge times are estimates only for fully discharged battery pack. Actual charge times may vary.

DC Peak Detection Charger Features:

- Variable charge rate from 0.3–1.2 amps
- Trickle charge
- Uses automobile 12V power outlet
- Charges 4- to 7-cell Ni-Cd and Ni-MH battery packs
- LED charge indicator

Charging the Aircraft Battery:

1. Using the dial on the side of the charger, select the charge rate .8 amps
Battery Capacity: 7.2V 600mAh Ni-MH
Typical Charge Time: 40 minutes
2. Connect the battery pack to the charger using the included adapter.
3. Connect the charger to the 12V power outlet in your automobile. The LED will continually blink while the battery charges.
4. Charging is finished when the LED indicator glows steadily. You should also notice at this time that the battery is warm to the touch.

Note: Although both the stock 6-cell 600mAh Ni-MH (PKZ1021) and the high performance 7-cell 600mAh Ni-MH (PKZ1025) battery packs perform well for indoor and outdoor flying, please consider the following: When flying in a small- to medium-sized gymnasium, use the 6-cell stock-pack. It is lighter in weight and also allows your Slo-V™ to fly slower. When flying outdoors the 7-cell pack offers more power for better loops and other maneuvers, as well as adds nose weight to help in light winds.

Note: Do not leave the charger and battery unattended during the charge process. While charging, place the battery on a heat resistant surface and constantly monitor the temperature of the battery pack. If the battery becomes hot at any time during the charge process, discontinue the charging immediately. Do not allow children to charge battery packs without adult supervision.

Important: The Slo-V flight battery should be charged shortly before flying. If you charge the battery 12 to 24 hours prior to flying, you should "re-peak" the battery before you fly by repeating the charging steps.

Step 4

Attaching Landing Gear

1. Locate the main landing gear and install it onto fuselage where shown.
2. Install tail landing gear where shown. Your Slo-V can now stand in order to attach the wing and tail.

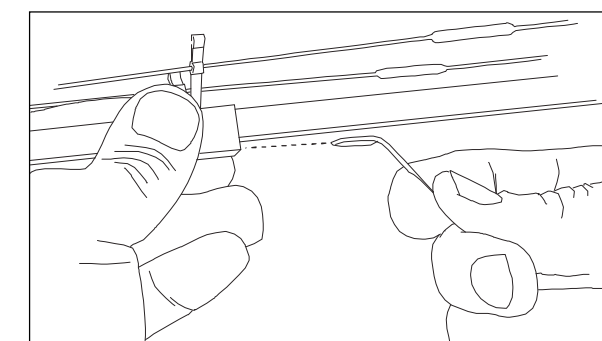
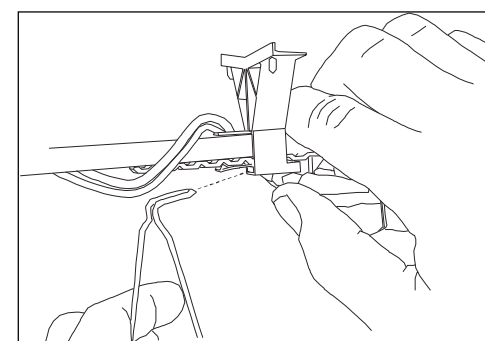

Step 5

Attaching and Adjusting the Wing

1. Open wing bag carefully. Locate the included braces that will secure the wing's correct dihedral. One brace will be applied to the leading edge and one to the trailing edge of the wing.
2. Unfold wing to see what the fixed dihedral will look like. Trial fit both braces without removing the paper from the tape on the braces.

Note: The brace for the leading edge will wrap around the top and bottom of the leading edge.

3. Once you are pleased with what the fit will be, peel the paper off of the tape from the leading edge dihedral brace and carefully attach it to the wing. Next, do the same with the trailing edge brace.
4. Locate the four strips (100mm x 40 mm) of transparent tape that have been supplied to help secure the braces to the wing. Secure these on the outer edges of both braces on the leading edge, starting at the top of the wing and wrapping around the leading edge to the bottom of wing. Do the same for the brace on the trailing edge of the wing.
5. Use the supplied white tape (305mm x 30mm) to re-enforce the center of the wing section. Simply start at the leading edge of the middle of the wing and attach all the way until you have come to the trailing edge of the wing.
6. Place wing on top of fuse, resting it on the two braces on the fuselage. One brace will hold the leading edge, one will hold the trailing edge. You can move the trailing edge brace in small increments as needed to allow the rear of the wing to rest properly on the brace prior to securing it.
7. Secure the wing by using 4 rubber bands. Stretch one rubber band from trailing edge brace post to leading edge post of one side. Do the same for the other side. Continue with the other two rubber bands so that a total of two rubber bands secure each side of the wing.

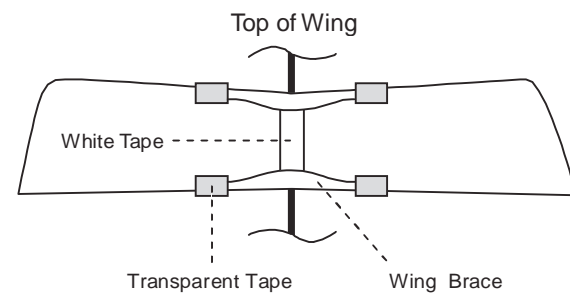
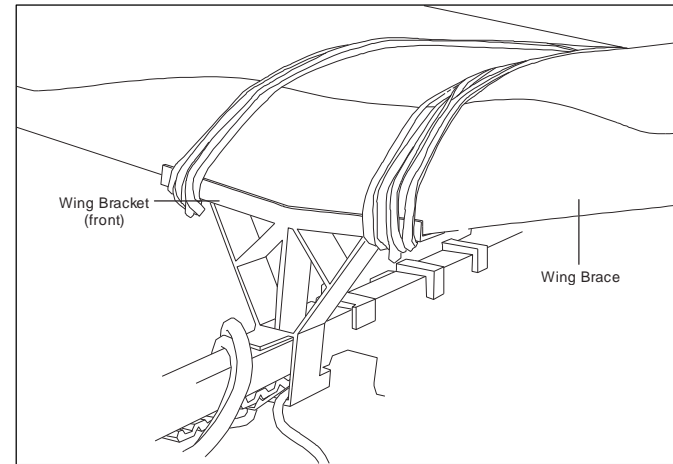

Note: Your Slo-V comes equipped with an exclusive adjustable wing position to allow you to optimize your flying, whether indoors or outdoors. If you are flying indoors, you may want to slide the wing a little further to the front, allowing your Slo-V just a bit more tail-heavy and slower. When flying outdoors, you may want to slide the wing slightly back toward the tail, allowing the plane to be a little nose-heavy, faster, and more stable and predictable in light wind.

Step 6

Attaching the Tail

1. Remove 2 thumb screws from plastic parts bag.
2. Locate the tail of Slo-V.™
3. Making certain the black V-shaped bracket is on the top of the tail, and the control horns are on the bottom of the tail, rest it on the fuse where it will be set. This will allow you to visually see where the holes of the fuse and the holes of the tail and bracket will match in order to secure the tail with the thumb screws.
4. Enter thumb screws from the bottom and tighten until tail is secured.
5. Taking notice that the pushrods cross each other, open up the clevis on one side of the pushrod and attach to tail at the bottom hole of control horn. Snap clevis shut and secure after this is done. Repeat for other side.

6. You may have to trim the tail prior to flight.

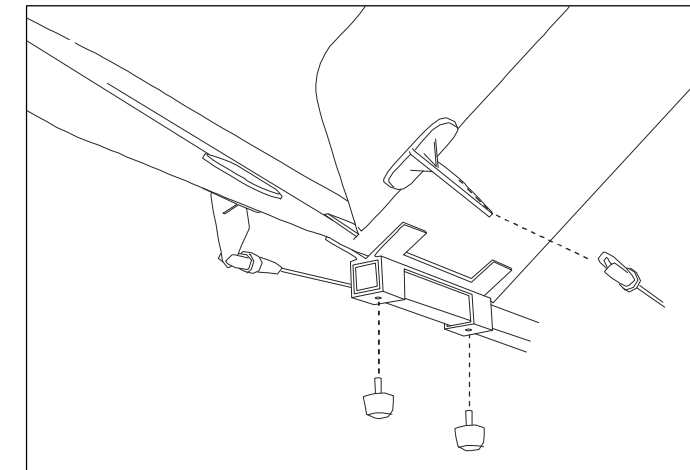

Step 7

Motor Test

1. Make sure the throttle slider is in the "off" position.
2. Attach charged battery to fuselage with included rubber band.
3. Turn on transmitter.
4. Plug in the flight battery.
5. Your Slo-V has a built-in throttle-arming feature which needs to "see" the throttle slider in the off position before it will spin the propeller. (**CAUTION:** Make sure that you, as well as loose clothing and hair, are away from propeller at all times!) Advance the throttle forward and the propeller will spin. The throttle-arming feature will need to be activated each time the battery is plugged into the airplane.
6. When finished with the motor test, continue to the next step.

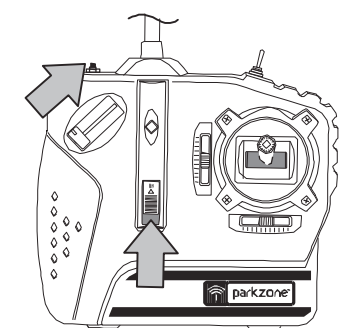
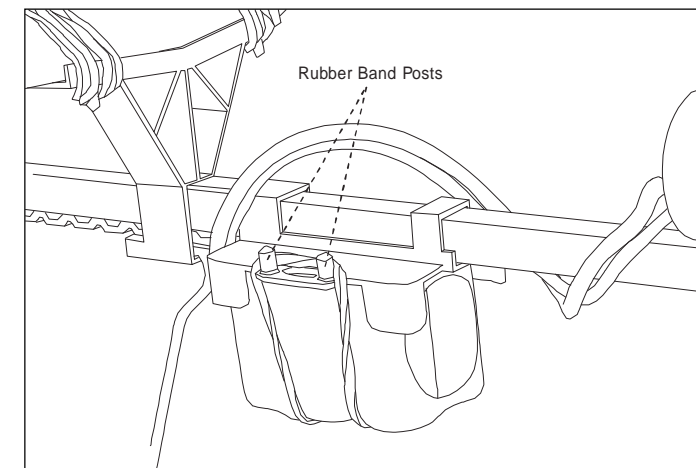

Adult Supervision Required

WARNING: Keep everything clear of the propeller and hold the plane securely. A moving propeller can cause severe injury.

Step 8

Tail Control Test

Warning: Keep everything clear of the propeller before starting the control test in the event that the motor is accidentally engaged.

Your Slo-V™ uses a V-tail to provide directional control. The V-tail functions as both rudder and elevator. To test the tail to ensure it functions correctly, simply follow these steps:

1. With the transmitter stick at neutral and both trim levers centered, the control surfaces of the tail should be at neutral. If this is not the case, you can make small adjustments to the trim levers. If these changes are not sufficient (with the stick and trim levers at neutral), you can remove

the clevis from the control surface on bottom of tail and turn clevis in or out as needed to move the control surface back to neutral.

2. Give the transmitter full right on the stick. The left tail control surface should deflect upward while the right one deflects downward.
3. Give the transmitter full left on the stick. The right tail control surface should deflect upward while the left one deflects downward.
4. Pull back on the stick and both control surfaces should deflect upward.
5. Push up on the stick and both control surfaces should deflect downward.

If you encounter any problems with your Slo-V responding properly to the transmitter, do not fly. Call Horizon Hobby Product Support at 1-877-504-0233.

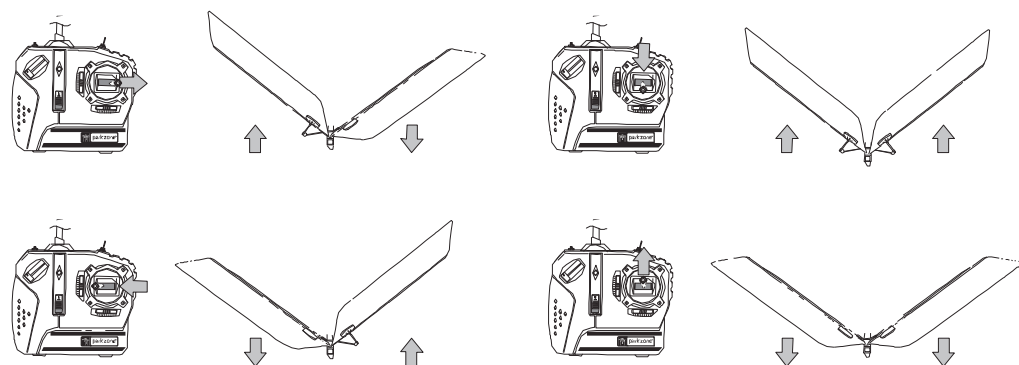

Step 9

Mode Change Flight Control™ System

Your Slo-V comes with the ability to change flight modes as you gain more experience and become more familiar with it. There are two modes that are selectable from the transmitter that you can choose for flying.

Mode A (Low Rate): Mode A is recommended for beginning your flight. The tail control travel will be limited in this mode, allowing you to become more familiar with your Slo-V. The switch on the top of your transmitter is at the “back” position when you are in Mode A.

Mode B (High Rate): Mode B no longer limits your travel. This mode is ideal for flying indoors (where you have limited space), as well as for all combat and other outrageous flying maneuvers. However, your Slo-V may be much easier to crash as well in this mode. The transmitter switch will be in the “front” position when you are in Mode B.

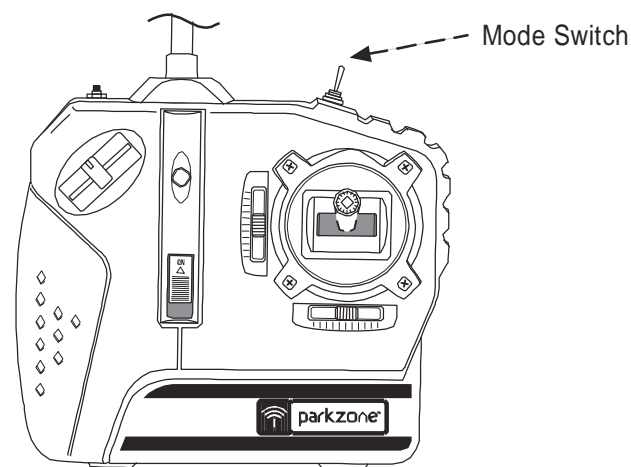

Step 10

Choose a Location

- A large, open grass field is ideal for flying your Slo-V.™
- Make certain that you do not fly near trees, buildings, or other areas that can restrict your view or interfere with your flying.
- An accomplished pilot can also fly the Slo-V in a large gymnasium or similar building.

Note: Flying indoors is recommended only for advanced pilots, as the smaller area obviously makes piloting the Slo-V more difficult.

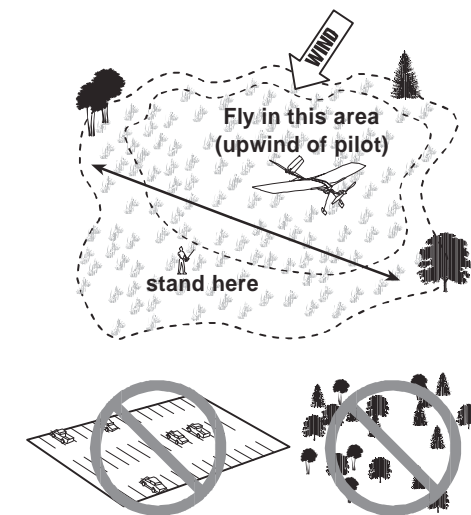

Step 11

Choose a Calm Day

You want to fly! However, you need to make sure that you fly in the conditions that will allow you to have the best success. This is when there is **little to no** wind (less than 5 mph).

To Check Wind Conditions:

1. Tie the included red ribbon to the transmitter antenna
2. Hold the transmitter antenna so that it is parallel to the ground and note how much the ribbon moves in the wind. If the ribbon hangs down, conditions are right to fly. However, if the angle between the antenna and the ribbon is less than 30 degrees, it is too windy to fly.

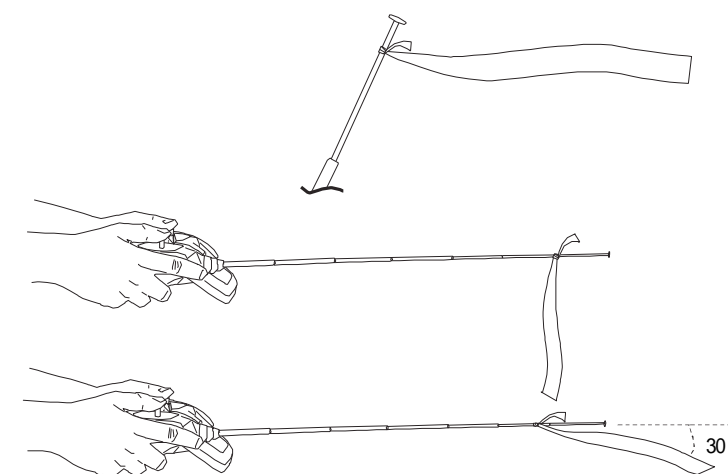

Step 12

Range Test

You will need two people to perform the range test: one to hold the plane and the other to give input to the transmitter.

Warning: The person holding the plane should be sure the propeller does not come into contact with any part of their clothing or body.

1. One person holds the transmitter, while the other person walks 100 paces away with the airplane.
2. Be sure the throttle slider is in the “off” position.
3. Extend the transmitter antenna completely and turn the transmitter on.

4. Plug the airplane battery into the fuselage.
5. As soon as the throttle slider is advanced, the propeller should spin quickly.
6. As the first person moves the transmitter controls at the same time, the other person watches to be sure the airplane's motor and tail controls operate smoothly.

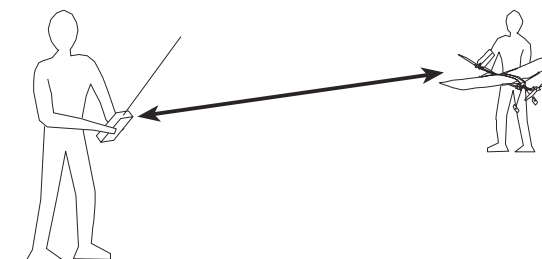

Step 13

Seek Assistance from an Experienced Radio Control Pilot

VERY IMPORTANT: The 3-channel control system is designed for the experienced radio control pilot and is not intended for the first time flyer. If you have successfully flown the Zone 2 or 3 HobbyZone airplanes, then you should be ready for the ParkZone™ Slo-V. However, first-time pilots of the Slo V should seek the assistance of an experienced RC flyer.

Crash damage is not covered under the warranty.

Step 14

Hand Launching Your Slo-V

1. Turn on transmitter.
2. Install and plug in aircraft battery.
3. Place your fingers of your launching hand just behind the servos on the fuselage.
4. With the power full on, firmly throw your Slo-V level and directly into the wind (if flying outdoors).
5. Keep steering into the wind and hold at full throttle until you have reached an altitude of at least 30 feet.

7. When you have reached this safe altitude, it is safe to steer in the desired direction as well as adjust the throttle input to help control altitude and speed.

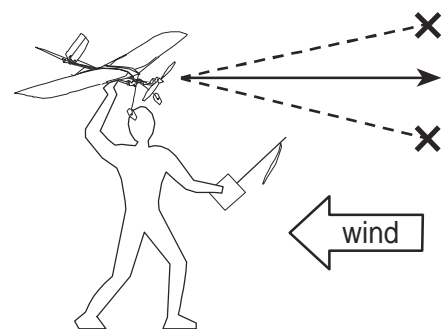

Step 15

Runway Takeoffs

1. Make certain aircraft battery is fully charged.
2. Select a smooth wide area from which to take to the sky. New asphalt or concrete is ideal.
3. Turn on transmitter.
4. Install and plug in flight battery.
5. Stand behind your Slo-V.
6. Making certain that nothing will be in your path, give the airplane full throttle. As you feel the tail wanting to rise, slowly pull back on the stick to allow the elevator to help give you the lift necessary. You should be able to leave the runway within 20 feet.

Do not pull back too far on the stick, as it can cause your Slo-V to stall and crash.

7. Keep steering into the wind and hold at full throttle until you have reached an altitude of at least 30–40 feet.
8. When you have reached this altitude, it is safe to steer in the desired direction, as well as adjust the throttle input to help control altitude, and speed input to help control altitude and speed.

Step 16

Flying

1. After launching, your Slo-V™ should climb at full throttle. Keep the throttle full on until you have reached an altitude of about 30 ft. At this same time, make sure that you are continuing to keep the airplane directed into the wind.
2. Make right and left adjustments as necessary to keep the plane headed directly into the wind.
3. After you have reached approximately 30 ft. of altitude, you can begin to make directional changes that you desire.
4. **Remember: Control range is 2,500 ft.** Do not allow the plane to get too far away from you. When the plane is further in the air it is harder to see and the winds are stronger.
5. Always keep the plane upwind from you. This way, the airplane will not be carried away from you by the wind.
6. Flying in too much wind is by far the number one reason for those who are inexperienced to crash or have fly-aways.

Do not fly if the wind is more than 5 mph.

Sharp Turns

In order to make a sharper turn, move the stick in the desired direction and add some up elevator (pull back on stick). The plane will make a sharper banking turn.

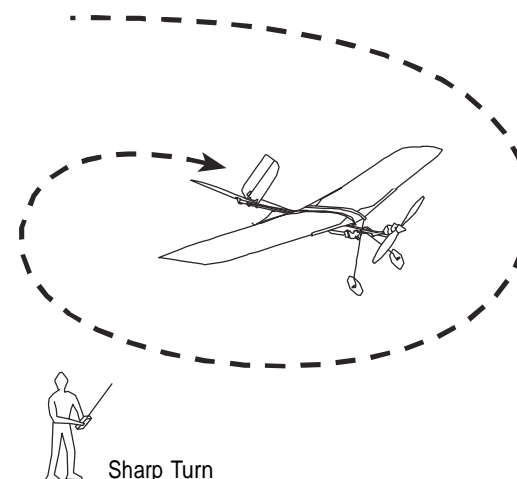

7. Avoid holding the stick full right or left for more than two seconds, as this will cause the plane to enter a spiral and could threaten your Slo-V.
8. Do not try to climb too fast by pulling all the way back on the stick (up elevator), or your plane may enter into a stall.
9. Damage/bends to the wings or tail can greatly affect flight control. Replace the damaged parts immediately.

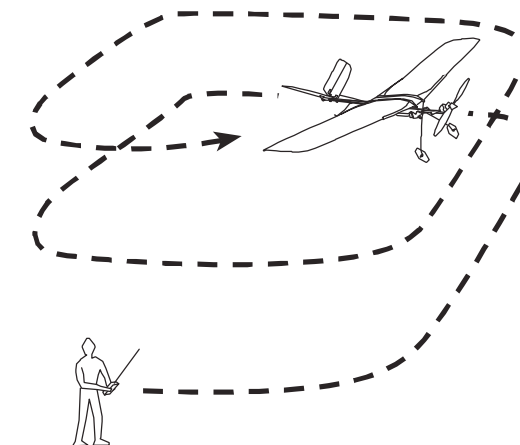

Note: With the throttle slider set at low or off (gliding), the plane will not turn as fast as when you are flying at or near full throttle.

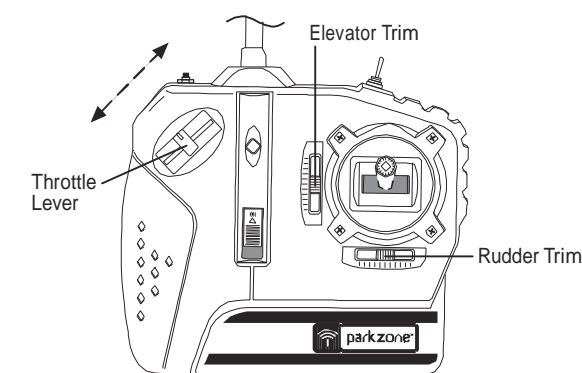

Step 17

Throttle Adjustment

1. Climb to an altitude of 50 feet or more with full throttle.
2. To achieve and maintain a level "cruising" altitude, reduce the power by moving the throttle slide down to approximately 50% of full-on. The throttle slide is proportional, so you can add or reduce throttle in small increments as needed to maintain the altitude that you desire.
3. To reduce altitude, reduce throttle
4. To increase altitude, increase throttle.

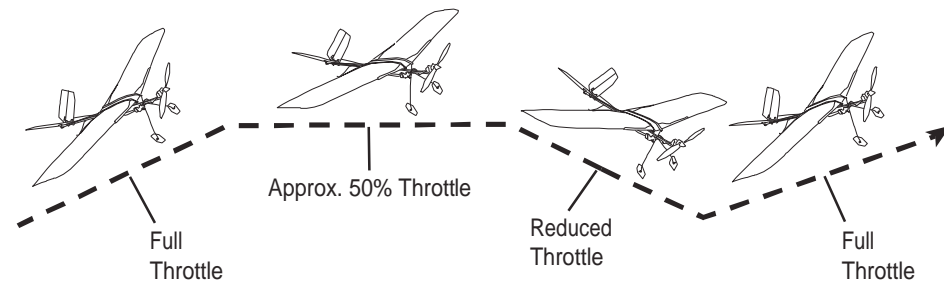

Step 18

Using Elevator

Your Slo-V™ is equipped with a third channel for elevator (pitch control). Pulling back on the stick provides up elevator. This allows for shorter takeoffs, better flares for landing, better climb rates, and more effective turns. However, pulling too far back on the elevator to climb too quickly could cause the airplane to enter a stall (make the nose of the plane come down). To avoid crashing from a stall, always maintain enough altitude to recover.

Just after a stall has occurred, the nose of the airplane will fall and the plane will look like it is diving. To pull out of a stall, simply pull back slowly on the stick (partial up elevator) once your Slo-V has built up airspeed. Remember, pulling back too quickly or for too long will once again cause the airplane to enter a stall. Effectively avoiding and recovering from stalls requires experience. Always seek the help of an experienced radio control pilot if you are not familiar with pitch control. Failure to do so, could result in a crash and significant damage to your airplane.

Step 19

Landing Your Slo-V

When you begin to notice that your Slo-V™ no longer climbs well under full power (normally after approximately 12–15 minutes), the battery is getting low and it is time to land. Bring in your Slo-V, directly into the wind and toward the desired landing spot. Gradually reduce throttle to reach an altitude of approximately 5 feet).

At this point, reduce throttle even more and your Slo-V should glide in softly for a landing.

Expert Tip: As you get better and more experienced at flying, try adding a bit of "up" elevator just prior to landing to "flare" the plane. With some practice, your landings should become smooth and on target.

WARNING: Do not attempt to catch the airplane or injury may occur. Remember, there is a spinning propeller on the plane that can cause injury! Also, be sure to cut power to the motor right before you land to prevent damage to the propeller.

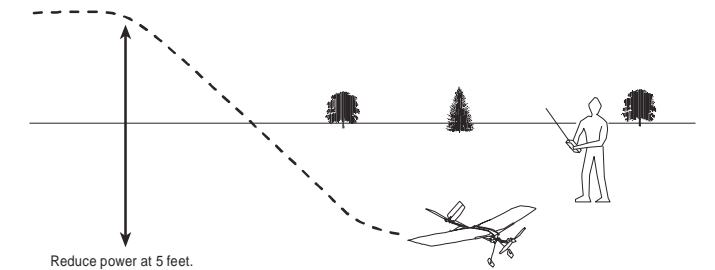

Step 20

Auto Cut-Off

When your flight battery gets low enough, this feature will automatically shut off the motor and save enough battery for the radio and tail control so you can land safely. If you are high enough and have some time

to rest the battery, you may re-arm the motor by moving the throttle slider to off and then advancing it again. This may give you an extra bit of power to adjust your landing. Do not re-arm more than once or twice, or you may lose your control power.

Step 21

Aerobatic Flight

Your Slo-V comes out of the box with the controls set for softer responses and at the outer holes of the control surfaces. However, once you get used to the flight characteristics and want to perform more aerobatic maneuvers you can change the amount of throw that is permitted by moving to the inner holes of the control horns.

After making any adjustments, always turn on the transmitter and center the transmitter trim levers, making sure the control surfaces are adjusted evenly.

Note: By making these changes, you will make the controls much more responsive. This makes the airplane much less forgiving and easier to stall. Remember, crash damage is not covered under the warranty.

Step 22

X-Port

Your Slo-V™ comes equipped with HobbyZone's exclusive X-Port™ feature. This allows you to add the Sonic Combat Module™ (HBZ4020) to your Slo-V for incredible aerial combat. With the SCM, you can engage in aerial combat with other X-port equipped aircraft.

When you successfully "hit" another person's SCM equipped aircraft, a high pitched sound is emitted. This signals their motor is disabled for approximately 10 seconds, while they maintain the ability to steer. This will allow them the opportunity to make a safe landing or position themselves to counter-attack.

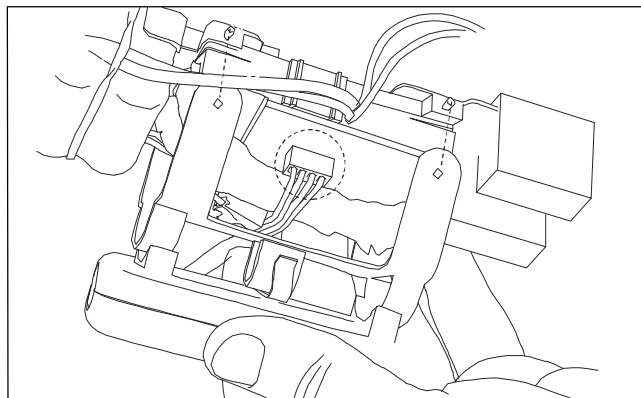

Simply attach the SCM on the designated space on the bottom of the fuselage. The firing button is at the top of the transmitter. When the button is pushed, a high-pitched sound will be heard signaling the SCM has been activated.

The Aerial Drop Module™ (HBZ6023) attaches to the exclusive X-port tray that has been included with your Slo-V. Simply plug-in the ADM and then attach it to the clip on the bottom of the X-port snap-on tray. The ADM will allow you to drop either streamer bombs or a parachute jumper, all of which are included in the ADM.

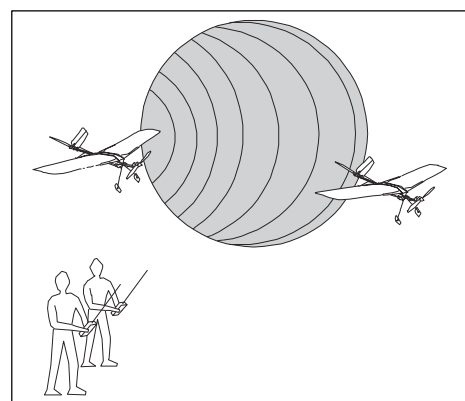
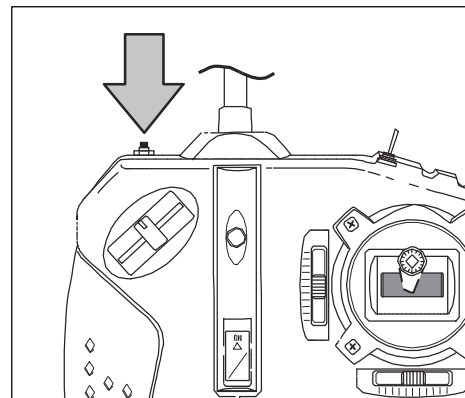

Warnings and Safety

1. Read and follow this manual completely, observing all instructions and safety directions. Otherwise, serious injury and damage can occur.
Think safety first.
2. Keep propeller away from body parts, even when it isn't spinning, as it could be turned on accidentally. Beware of hair becoming entangled in the propeller, especially while launching the Slo-V.™
3. Do not fly when it's too windy or you may lose control and crash, causing injury or damage. Never fly near people, vehicles, train tracks, buildings, power lines, water, hard surfaces or trees. Never allow any one to attempt to catch the airplane while it's in flight or serious injury can result.
4. Adult supervision is recommended for ages 14 and under.
5. Battery charging: Only use a battery charger intended for use with the flight battery. Never leave charger unattended while charging, to help prevent over-charging. Place the battery on a heat resistant surface; do not lay it on carpet or upholstery while charging.
6. Never cut into the battery charger or airplane wires or serious injury can occur. Causing the battery to "short out" (crossing negative and positive bare wires) can cause fire, serious injury and damage.
7. Hold the plane securely, and keep all body parts away from the propeller when the flight battery is plugged in. When you finish flying the Slo-V, always unplug the battery before you turn off the transmitter.
8. Never fly on the same frequency as another RC vehicle in your area. The frequency of the Slo-V is shown on stickers on the back of the transmitter.

Success Tips

1. Don't fly in winds over 5 mph! First-time pilots should get help from an experienced radio control pilot during first flights.
2. Choose your flying field carefully—grass and soft ground with 300-foot diameter is optimal to fly the Slo-V. Make sure there are no obstacles that will get in your way when flying, such as trees or buildings. Make sure you do not fly where there are pedestrians who could be hurt by the airplane.
3. Remember that holding the right stick full over for too long can cause the airplane to spiral dive and crash. At the very first sign of the Slo-V beginning to spiral down, immediately release the stick, and give the opposite turn to pull out of the spiral. After this is done and you once again have control of the Slo-V, pull back on the elevator to level flight and level the wings.
4. Don't attempt to fly or do maneuvers beyond your flying abilities without seeking the assistance of an experienced pilot.
5. If you're gliding with the motor off, allow the Slo-V more area for turns.
6. Position yourself at your flying field to keep the sun at your back and out of your eyes. Wear sunglasses on bright days.
7. Keep the Slo-V upwind, especially on windy days, to prevent it from "flying away." The wind is normally stronger at higher altitudes than it is on the ground.
8. Keep your plane in front of you so you don't have to turn in circles as you fly. Try to avoid flying directly overhead.
9. Do not attempt to fly indoors until you have become very accomplished at flying your Slo-V outdoors.

Step 23

Repairing Minor Damage

If you happen to crash and part of the tail or wing breaks, it can be repaired by using packing tape to cover the missing pieces. See this manual for a complete list of replacement parts for your Slo-V.

Troubleshooting

PROBLEM	POSSIBLE CAUSE	SOLUTION
Unit does not operate	<ol style="list-style-type: none"> 1. Transmitter "AA" batteries are depleted or installed incorrectly, indicated by a dim or unlit LED on transmitter or the low battery alarm. 2. No electrical connection. 3. Flight battery not charged. 	<ol style="list-style-type: none"> 1. Check polarity installation or replace with fresh "AA" batteries. 2. Push connectors together until they "click." 3. Charge battery fully.
Aircraft keeps turning in one direction	<ol style="list-style-type: none"> 1. Tail control surfaces not set up correctly. 2. Wing is not centered. 	<ol style="list-style-type: none"> 1. Review control surfaces. 2. Center wing prior to each flight.
Aircraft will not climb	<ol style="list-style-type: none"> 1. Battery is not fully charged. 2. Tail needs adjusting. 	<ol style="list-style-type: none"> 1. Charge battery fully shortly before flying. 2. Adjust tail screws or trim levers.
Aircraft keeps pitching up steeply	<ol style="list-style-type: none"> 1. Wind is too gusty or strong. 	<ol style="list-style-type: none"> 1. Postpone flying until the wind calms down.
Aircraft is difficult to control	<ol style="list-style-type: none"> 1. Wing or tail may be creased or damaged. 	<ol style="list-style-type: none"> 1. Replace or repair.

Replacement Parts

Make sure that you keep your Slo-V™ in the air. Replacement parts are available at your local hobby shop or from Horizon Hobby (www.horizonhobby.com). Please try your local retailer first. By supporting your local hobby store, they will be there when you need them!

Item	Description	Retail
PKZ1302	Decal Sheet: Slo-V	4.99
PKZ1304	Prop Shaft w/gear: Slo-V	2.29
PKZ1306	Landing Gear Set: Slo-V	5.49
PKZ1310	Rubber Bands (6): Slo-V	0.99
PKZ1314	Carbon Fuselage w/tray: Slo-V	10.99
PKZ1316	Motor w/pinion: Slo-V	9.99
PKZ1318	Wing & Pushrod Bracket (3): Slo-V	4.99
PKZ1320	Wing Kit: Slo-V	14.99
PKZ1322	Pushrods w/clevis (2): Slo-V	2.59
PKZ1324	Tail Set: Slo-V	8.99
PKZ1326	Tail Mount Set: Slo-V	1.49
PKZ1328	Complete Gear Box: Slo-V	6.99
PKZ1251	ESC/RX: CH 1: F-27, Slo-V	29.99
PKZ1252	ESC/RX: CH 2: F-27, Slo-V	29.99
PKZ1253	ESC/RX: CH 3: F-27, Slo-V	29.99
PKZ1254	ESC/RX: CH 4: F-27, Slo-V	29.99
PKZ1255	ESC/RX: CH 5: F-27, Slo-V	29.99
PKZ1256	ESC/RX: CH 6: F-27, Slo-V	29.99
PKZ1003	Propeller w/spinner: Slo-V	4.29
PKZ1025	7.2V 600mAh Ni-MH Battery: Slo-V	23.99
HBZ1026	DC Peak Charger (1.2 Amp)	19.99
HBZ1027	Peak Detect Plug Adapter	1.79
PKZ1130	Mini Servo (5W)w/arms: F-27,J-3, Slo-V	9.99
PKZ1241	TX: CH 1, 26.995: F-27, Slo-V	32.99
PKZ1242	TX: CH 2, 27.045: F-27, Slo-V	32.99
PKZ1243	TX: CH 3, 27.095: F-27, Slo-V	32.99
PKZ1244	TX: CH 4, 27.145: F-27, Slo-V	32.99
PKZ1245	TX: CH 5, 27.195: F-27, Slo-V	32.99
PKZ1246	TX: CH 6, 27.255: F-27, Slo-V	32.99
HBZ1058	TX Antenna	4.99
HBZ6057	TX Battery Cover	2.50

Optional Parts:

ParkZone™ offers some optional parts to give you the best performance possible. See your retailer for the following parts:

HBZ4020	Sonic Combat Module	23.99
HBZ4025	Stealth Target w/sensor	23.99
HBZ6023	Aerial Drop Module	19.99
HBZ6513	Alligator Clip: 12V Lighter Adapter	3.99
PKZ1021	8.4V 600MAH Ni-MH Battery: J-3, Slo-V	24.99

Warranty and Follow-Up Procedures

Due to the nature and operation of this product, the warranty does not extend beyond the initial preflight testing. Carefully check the parts and operation BEFORE your first flight.

Damage incurred during flying, landing, crashing or modification is not covered under the warranty.

Warranty: Horizon Hobby, Inc. guarantees this product to be free of defects in material and workmanship. If you discover defects during the very first preflight testing, please call our Product Support staff toll-free at 1-877-504-0233. If you are directed by them to return the product to our Service Center, you will be provided with a RA (Return Authorization) number. If, in our opinion, after inspecting the product, we determine it to be defective, we will repair or replace it at our discretion.

If you are directed by our Product Support staff to return the airplane, please follow these instructions:

1. Unplug the battery from the airplane.
2. Pack the complete Slo-V™ (all components in the original box) and put into a sturdy shipping carton for protection.
3. Include your complete name and address information inside the carton, as well as clearly writing it on the outer label/return address area. Include detailed information explaining the nature of the problem(s) encountered.
4. Please date your correspondence and be sure your complete name, address and daytime phone number appear on this enclosure. Please include your original dated sales receipt.

Mail to the address below.
Horizon Service Center
Attn: ParkZone Dept.
4105 Fieldstone Rd.
Champaign, IL 61822